

Introduction

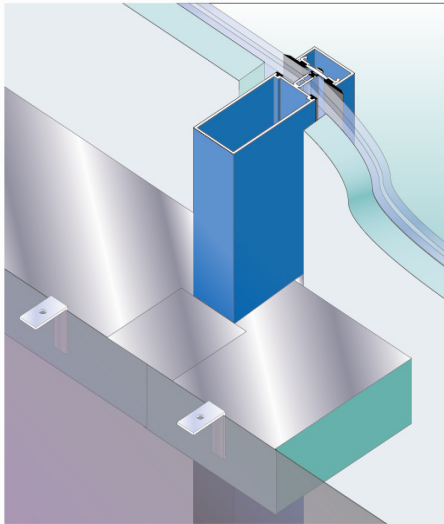

Lamatherm *Certifire* approved **CW-FS SYSTEMS** offer an extensive range of solutions for fire stop, smoke stop and sound barrier requirements in all architectural cladding panel applications.

Based on the experience gained through being the premier supplier to the UK curtain walling market for over twenty years, the products represent an unrivalled

combination of fully qualified performance, practical installation and service benefits.

The primary function of the CW system is to maintain continuity of fire resistance by sealing the gap between the compartment floors or walls and the external curtain wall both horizontally and vertically

Advantages

- Tested utilising the principles of BS 476, Part 20 & BS EN 1366-4:2006
- Certifire approved CF 563
- Provides up to 300 minutes fire integrity and insulation
- Suitable for both Horizontal and Vertical applications
- Provides a smoke & fire seal
- Qualified acoustic performance
- Economical and easy to install
- Suitable for use in cavities / voids up to 1200mm wide
- Supplied in full sheets or pre-cut in strips to suit specific void dimensions.
- Quality assured to BS EN ISO 9001

Description

Lamatherm CW-FS - The patented method of manufacture provides a resilient lateral compression property which assists installation, ensures the requisite tight fit and thereby enhances fire integrity.

Throughout the range, the materials comprise a one-piece product having a pre-compressed non-combustible

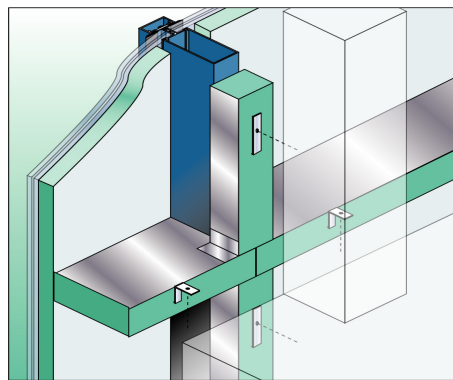

Fig 1: Horizontal & Vertical CW fire stops at curtain wall

rockfibre core. The products also have integral aluminium foil facings to provide a Class O rating and excellent resistance to smoke.

As standard, the materials can either be supplied as pre-cut units to suit a quoted void size or in 1200 X 1200mm sheet form for cutting on site

Lamatherm CW FS systems also offer an unrivalled combination of independent third party *Certifire* approval performance data, for both horizontal and vertical applications. **Certificate N^o CF 563**

The systems can offer tested fire rating options ranging from 15mins to 5 hours and can accommodate cavity widths up to 1200mm.

In addition to providing an effective seal against the passage of smoke and fire the products will also function as an effective acoustic barrier and plenum lining.

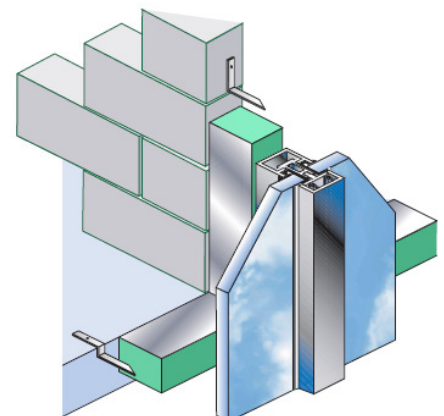

Fig 2: Horizontal & Vertical CW fire stops at party floor and wall

Standard systems

The materials can be either supplied as pre-cut units to suit a quoted void size or in sheet form for cutting on site.

Standard sheet products are supplied 1200 x1200 mm which may prove beneficial when the actual void size is not known or where it varies significantly. (**Note** that when ordered in sheet form, the requisite quantity of fixing brackets needs to be purchased separately)

Pre-cut products are available in 1mm increments of width so as to provide a tight compressive fit within the cavity. Each pre-cut CW unit is supplied with fixing brackets to locate the material into position. The standard fixing brackets are supplied in 1mm galvanised mild steel in flat form that is complete with a pre-notched facility for folding on site.

All holes are to be drilled to suit the varying site conditions. Different size brackets are available according to the cavity size – refer to **Table 1**

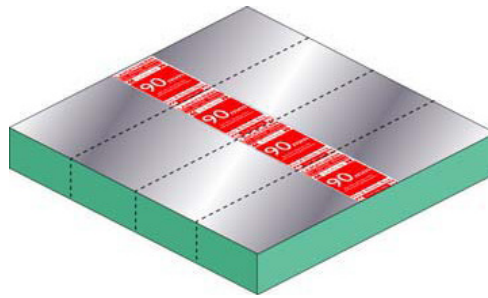

CW-FS fire stop systems can be supplied in sheets for cutting on site

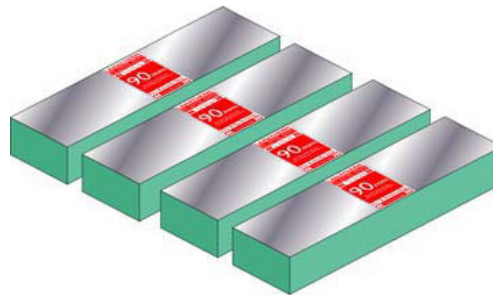

Fire stop systems can also be supplied pre-cut into strips to suit the measured void size.

Installation - Principles

The CW material must be installed with the un-faced mineral fibre in contact with the sides of the cavity, the aluminium foil smoke barrier facings will be positioned top and bottom i.e. remains visible to the installer. For all installations the CW seals are to be sized to provide the correct compression allowance.

For all void sizes: see CF 563

Note: Additional material allowances should be included whenever façade deflection is anticipated.

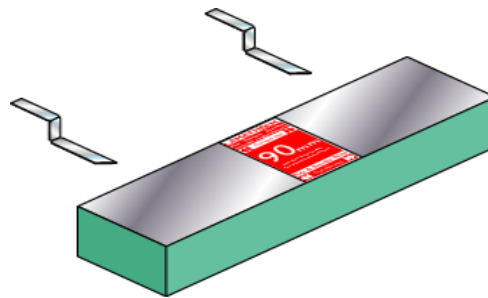

Fixing brackets are impaled into the CW-FS fire stop material at nominal 600mm fixing centres i.e. 300mm from each end.

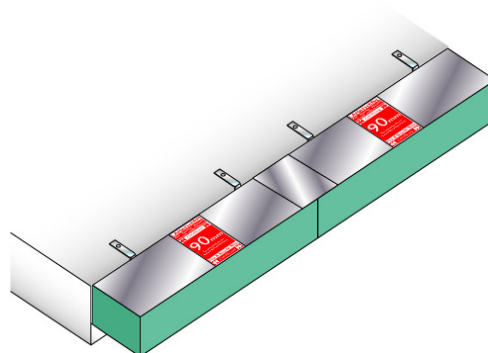

The cut strips are inserted within the cavity with the fixing brackets simply located over the slab edge. **Note!** The brackets should be mechanically fixed to slab where void sizes exceed 400mm

Installation CW-FS (Horizontal)

For all installations the cut strips are located with fixing brackets which are impaled into the material at mid-thickness, at nominal 600mm fixing centres i.e. 300mm from each end. For horizontal applications, the cut strips are then inserted within the cavity with the fixing brackets located over the edge of the concrete floor slab.

Note! The brackets should be mechanically fixed to slab where void sizes exceed 400mm.

Build the CW into the cavity to provide the necessary compression.

For all void sizes: see CF 563

Ensure that there are no gaps and that all joints, including the intersections of horizontal / vertical installation, are tightly abutted and sealed with Lamatherm self adhesive Class O foil tape to ensure the integrity of the smoke barrier.

A range of support brackets for CW-FS horizontal cavity barriers are available for cavity widths of up to 1200mm (see table 1 for appropriate type and quantity).

The fixing brackets should be trimmed, if necessary, to approximately 75% of the cavity width. The standard fixing brackets are supplied in 1mm galvanised mild steel in flat form that is complete with a pre-notched facility for folding on site. All holes are to be site drilled to suit the varying site conditions.

Where the void is smaller than the section available, the product can be trimmed on site with a sharp serrated knife providing that the compression allowance is maintained. Also, if used in sheet form, the product must be cut to provide the requisite compression fit.

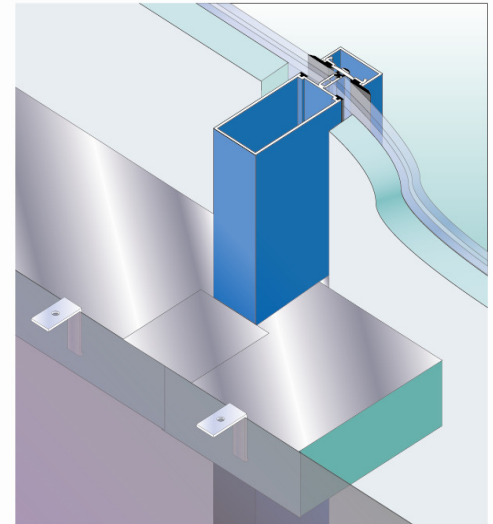

Fig 3a
Horizontal CW fire & smoke stop installed at junction between floor slab and curtain wall.

Table 1: CW-FS Horizontal Brackets & Fixing Centres

Bracket Reference	Min Void Size (mm)	Max Void Size (mm)	No Brackets	Bracket Centres (mm)
B65/110	50	150	2	600
B195	151	240	2	600
B355	241	400	2	600
B355	401	500	4	300
B600	501	600	3	400
B900	601	1200	3	400

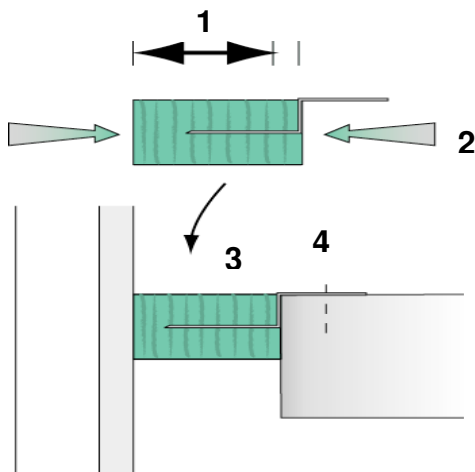

Fig 3b
Horizontal CW Fire and smoke stop assembly

- [1] Cut the CW material to provide the required compression allowance as stated in CF 563
- [2] Impale the correct fixing brackets at mid thickness. Trim bracket to 75% of cavity width if necessary.
- [3] Apply compression to install the assembled CW unit into the cavity.
- [4] Fixing brackets located over edge of concrete floor slab (Mechanically secure the fixing brackets to the slab for voids > 400mm)

Installation CW-FS - Detailing

For the interface with the mullion condition we recommend that the CW-FS is notched with the joint between adjacent product being along the centre line of the mullion as shown below

For curtain wall systems with 1500mm mullion centres we recommend the use of standard 1200mm product complete with a notch at the right hand mullion, together with a 300mm product complete with a notch to the left hand mullion.

Note the smaller 300mm product length is secured with two fixing brackets.

We specify that all small portions of product are fixed with two fixing brackets as part of the system

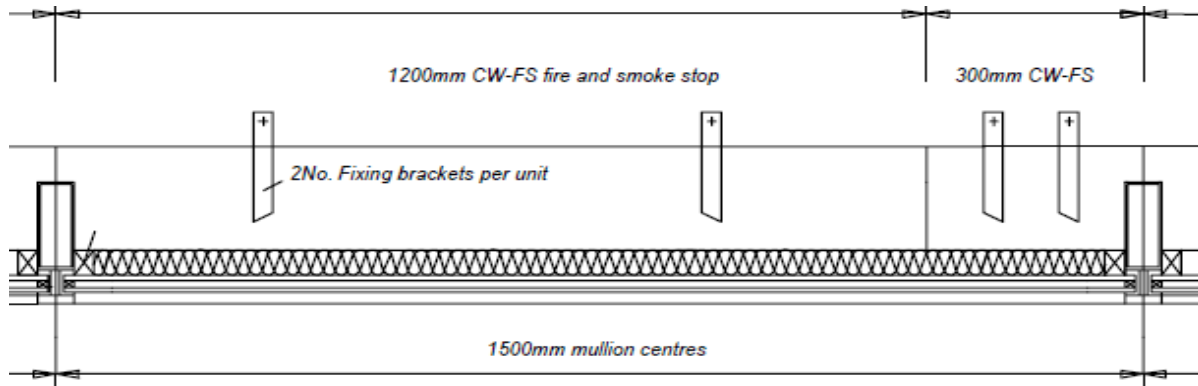

Figure 4. CW-FS fire and smoke stop is easily cut onsite with a sharp serrated knife to form a tight resilient seal around mullion details.

For the interface with the spandrel panel at the mullion position we recommend the use of a cut portion of CW product to suit the void (cut oversize to maintain compression). This is then bonded into position with trowel grade Lamatherm Fire & Acoustic Gap Sealant.

Smaller voids and/ or particularly difficult situations can be treated by the additional application of cartridge grade Lamatherm Fire & Acoustic Gap Sealant (intumescent acrylic) to make good joints, areas of missing material or complex details.

The CW material is easily cut on site with a sharp serrated knife to form a tight resilient seal around mullion details and structural brackets etc.

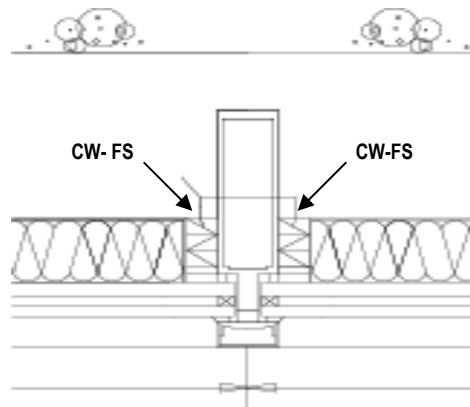

Figure 5. Small cut sections of CW-FS fire and smoke stop used to infill all voids at interface with mullion. Bond into position with Lamatherm Fire and Acoustic Gap Sealant.

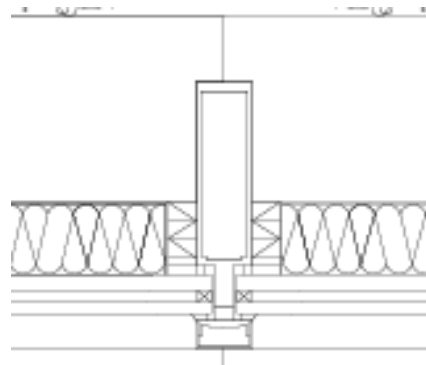

Figure 6: CW-FS fire and smoke stop between slab edge and spandrel panel.

Fire specification & system selector

Lamatherm **Certifire** approved CW Fire stop systems have been tested and assessed on proven fire performance to BS 476 :Part 20, and provides up to 300 minutes fire integrity and insulation.

Each system option has been formally assessed by the Loss Prevention Council to meet the relevant performance ratings given in the tables below Verification of fire

performance is available upon request.

CW Fire & Smoke Stops provide continuity of fire resistance across the cavity when aligned with fire rated elements so as to maintain compartmentation.

The correct system is simply selected by matching the fire resistance requirements to the CW system type and void size.

Table 2. summarises the nominal fire rating for **Horizontal applications** together with confirmation of its' void size limitation and standard dimensions.

Table 3 summarises the nominal fire rating for **Vertical applications**

Table 2: CW-FS Horizontal application: Fire ratings, void size and bracket types

Void size >	50-150mm	151-240mm	241-400mm	401-500mm	501-600mm	601-1200mm
30 Minutes	CW-FS30	CW-FS30	CW-FS30			
	75mm	75mm	75mm			
	2 No. B110	2 No. B195	2 No. B335			
60 Minutes	CW-FS60	CW-FS60	CW-FS60	CW-FS60	CW-FS60 X	CW-FS60 SB
	90mm	90mm	90mm	120mm	120mm	120mm
	2 No. B110	2 No. B195	2 No. B335	4 No. B355	3 No. B600	3 No. B900
120 Minutes	CW-FS120	CW-FS120	CW-FS120	CW-FS120	CW-FS120 X	CW-FS120 SB
	120mm	120mm	120mm	175mm	175mm	175mm
	2 No. B110	2 No. B195	2 No. B335	4 No. B355	3 No. B600	3 No. B900
300 Minutes *	CW-FS300	CW-FS300	CW-FS300			
	175mm	175mm	175mm			
	2 No. B110	2 No. B195	2 No. B355			

* CW FS300 system is provided with 75mm rebated joints as standard.
Fire performance to BS 476 Part 20 Test reports : WFRC 136497, Certifire approval No CF 563

Table 3: CW-FS Vertical application: Fire ratings, void size and bracket types

Void size >	50-150mm	151-240mm	241-400mm
30 Minutes	CW-FS30	CW-FS30	CW-FS30
	75mm	75mm	75mm
	2 No. B110	2 No. B195	2 No. B335
60 Minutes	CW-FS60	CW-FS60	CW-FS60
	90mm	90mm	90mm
	2 No. B110	2 No. B195	2 No. B335
120 Minutes	CW-FS120	CW-FS120	CW-FS120
	120mm	120mm	120mm
	2 No. B110	2 No. B195	2 No. B335
300 Minutes *	CW-FS300	CW-FS300	CW-FS300
	175mm	175mm	175mm
	2 No. B110	2 No. B195	2 No. B355

* CW FS300 system is provided with 75mm rebated joints as standard.
Fire performance to BS 476 Part 20, Certifire approval No CF 563

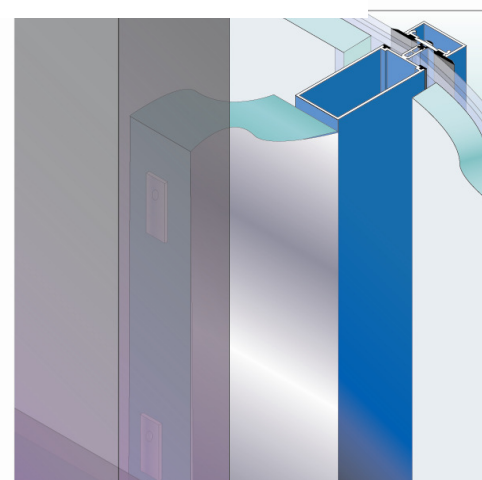

Figure 7. CW fire & smoke stop installed at junction between vertical wall and mullion

Movement characteristics – Curtain Walling & External Façade Deflection

The qualification of proprietary fire stop systems are typically limited by the condition that they must be installed in a static environment. However, for curtain walling applications it is imperative that the installed seal is able to function effectively with due regard to all designed movement serviceability limits. Accordingly, Lamatherm recognise that curtain walling and cladding façade systems will deflect due to:

- *Positive windload.*
 - *Negative windload.*
 - *Occupational live load.*
- The above are covered by BS 6399.**

Typically, a project may stipulate that the curtain walling system may have the following allowable deflection limits: -

- *15mm over 1No. panel of glass.*
- *20mm between fixing positions.*

These factors may inevitably combine to preclude the suitability and therefore, use of certain systems e.g. high density material slab products. However, the CW-FS fire stop systems are very effective for their function within curtain walling as the unique material construction can accept the cyclical *negative and positive* wind and live loads imposed on the façade.

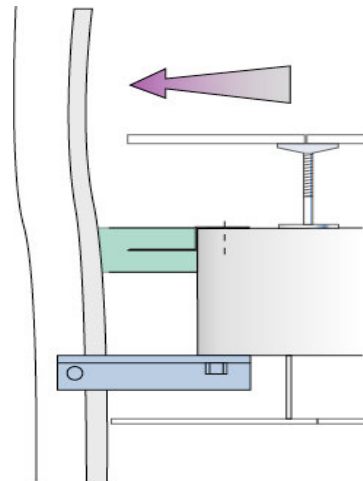

Figure 8. Section indicating vertical façade deflection due to negative windload.

Design issues

Important factors for the application of fire stops within curtain wall façades: -

- Review the position of fire stop and distance from fixing bracket connection.
- Ensure the structural engineer specifies the vertical façade deflection.
- Review the curtain wall expansion and any floor slab/building movement.
- Review transom /mullion deflection.

Upon confirmation and consideration of the above parameters, the required fire stop compression factor can be assessed for the specific project application.

Note 1: Lamatherm CW-V fire stop systems can accommodate façade deflection due to their unique construction. However, installation of the correct material size is important so as to ensure that integrity is maintained.

Note 2: On a project basis, consider both inward and outward deflection requirements for the system

Installation issues

As standard, the CW material must be compressed within the void to maintain the integrity of the seal.

Vertical applications, where the façade deflection may be up to 20mm, we recommend that you calculate the design deflection of the external façade system in both positive and negative wind load situations.

Then follow CF 563 + the design deflection of the system.



Figure 9. Section indicating vertical façade deflection due to positive windload.

Acoustic performance

The CW range additionally provides an effective sound barrier as the material construction and inherent properties of the mineral fibre core afford the CW exceptional acoustic performance.

Also, the foil facings and the additional sealing of joints with foil tape all serve to provide improved air tightness.

Sound reduction between floors

The installation of the CW SYSTEMS

within an external curtain wall cavity will significantly increase the floor-to-floor attenuation.

As an example, the installation of 120mm thick CW-FS120 within the cavity will increase the transmission loss via the tortuous sound path by approximately **25dB**.

The precise value will depend upon the specifics of the construction.

Table 4 confirms values for Weighted Sound Reduction Index (Rw) based on laboratory tests to determine airborne sound transmission in accordance with BS EN ISO 140-3 : 1995, BS 2750 Pt 3 :1995.

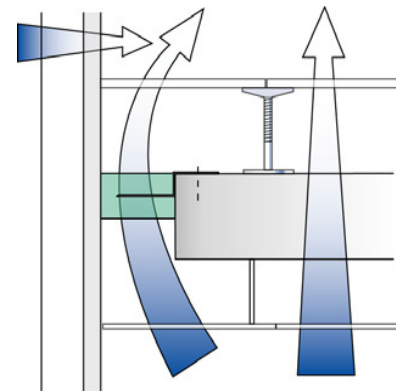

Figure 10. CW provides improvement to floor-to-floor sound reduction. For a given performance specification, the CW can provide the shortfall between the target attenuation and the value afforded by the other elements of construction e.g. raised access floor, suspended ceiling etc

Table 4: Weighted Sound Reduction Indices

Note: acoustic performances shown ignore the presence of raised access floor and suspended ceiling

System	Thickness	Rw (dB)
CW-FS 30	75mm	21 dB
CW-FS 60	90mm	22 dB *
CW-FS 120	120mm	25 dB
CW-FS 300	175mm	27 dB *

*Note: * Rw value interpolated from test results. Sound Research Laboratories Ltd. Test report No. : C/99/5L/7743/1*

Enhanced Acoustic Performance

AB Acoustic Barriers

Lamatherm offer a range of complementary acoustic mass overlay materials which can further enhance the overall acoustic performance of the construction.

AB barriers are extremely quick and easy to install and are suitable for improving sound performance within all curtain walling environments.

The AB acoustic barriers are factory produced multi-layer composite materials, consisting of Class 0 foil faced Polymeric layer bonded to a flexible acoustic foam.

The products are available in two grades according to the acoustic performance requirement, namely **AB5 & AB10**

Figure 11. Improved sound performance

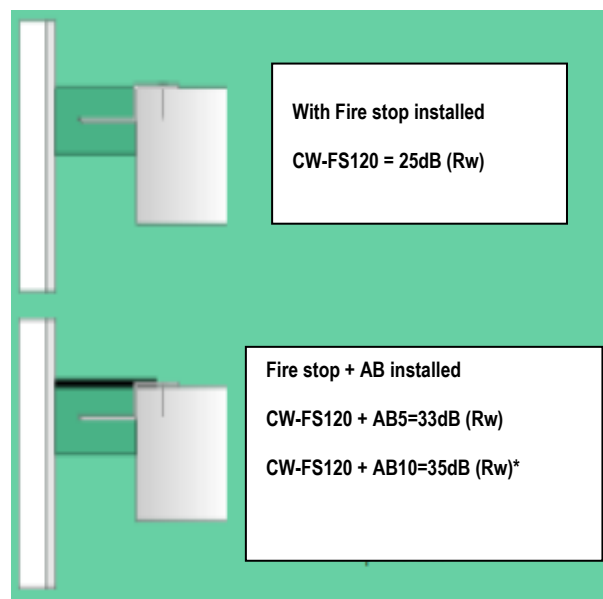

Note that the actual performance will be dependent on a number of factors including the design, choice of materials and degree of fit between components.

Table 5: AB Acoustic performance table

System	Surface Mass (Nominal)	Rw (dB)
AB5	5 kg/m2	25 dB
AB10	10 kg/m2	28 dB

Regulations guidance

Approved Document B to the Building Regulations requires that cavity barriers must have a minimum standard of fire resistance of 30 minutes integrity and 15 minutes insulation with regards to BS 476 : Part 20 : 1987 criteria respectively.

The Loss Prevention Council's 'Design Guide for the Fire Protection of Buildings' states that cavity barriers have 30 minutes integrity and minimum 30 minutes fire insulation

The 'Standard Performance Criteria' for fire & smoke stopping issued by the **Centre for Window and Cladding Technology** states: -

'There shall be continuity of time temperature rated fire and smoke stopping between the curtain wall and compartment walls and floors. Any spaces or cavities between the two shall be effectively stopped against the spread of smoke and flame. The fire resistance of such stopping shall be equal to that required of the compartment floor or wall against which it abuts.'

Lamatherm CW-FS Fire Stops are used to maintain the continuity of the fire resistance by sealing the gap between compartment floors (and walls) and the external curtain walling façade or any other external cladding systems.

Cavity Barriers ... a definition

"A construction provided to close a concealed space against penetration of smoke or flame, or provided to restrict the movement of smoke or flame within such a space

Lamatherm CW-CB/FS 30

Developed in recognition of the more demanding requirements of the 'Design Guide for the Fire Protection of Buildings' as issued by The Loss Prevention Council.

Fire stops ... a definition

'Sealing an imperfection of fit or design tolerance between fire rated elements of a building to restrict the passage of fire and smoke for the same period of fire resistance.'

For the purpose of Lamatherm product

terminology, the 'imperfection of fit' is considered to be the discontinuity between the edge of the structural frame (slab or wall) and the interface with the external cladding system. Compartment floors or walls may typically have the following fire ratings: - 1 hour, 2 hour, up to 4 hours.

Lamatherm CW-FS60

Is suitable for installation in alignment with a 1 hour rated compartment wall or floor to provide continuity of fire resistance across the cavity.

Lamatherm CW-FS120

Is suitable for installation in alignment with a 90 minute or 2 hour rated compartment wall or floor.

Lamatherm CW-FS300

Is suitable for installation in alignment with a 4 hour compartment wall or floor.

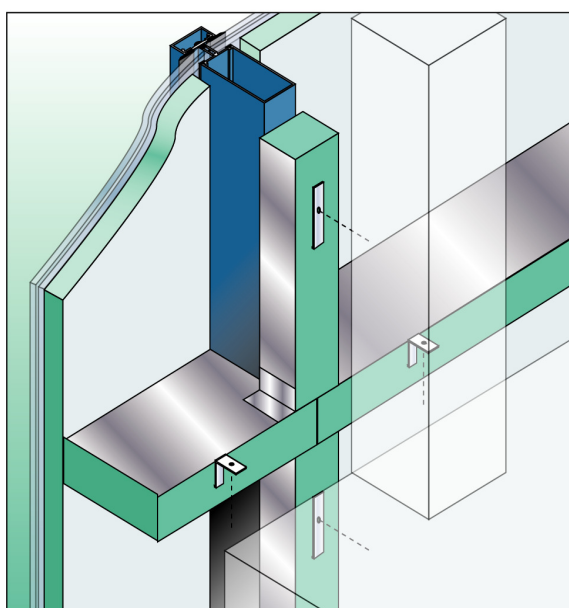

Figure 12:
Horizontal & Vertical CW fire stops and fixing brackets

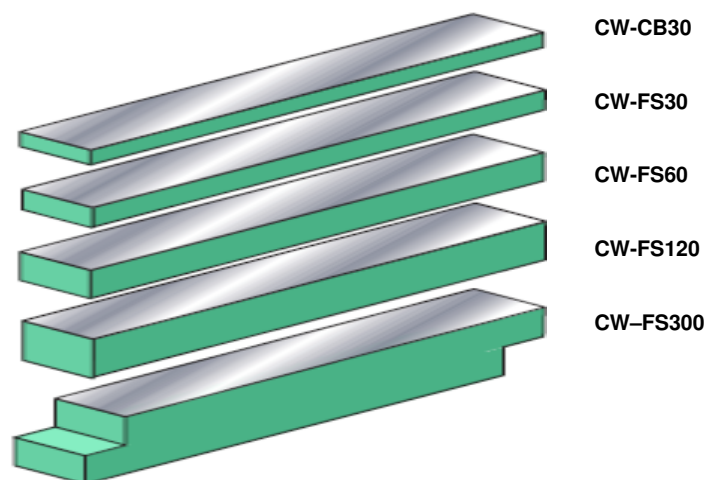

Figure 13.
CW provides a comprehensive range of systems to suit the fire performance required

CW Ordering procedure

- Indicate contract title and location of project
- Specify fire rating required
- Specify void size or schedule of sizes.
- Confirm total linear metres required.
- Specify if sheets or pre cut strips required. (see information below)
- Specify bracket type and quantity required.
- Specify foil tape requirement.
- Specify Fire and Acoustic Gap Sealant requirement.

Sheet products (Square edged)

1200mm x 1200mm
 Thickness: 75, 90, 120 & 175mm to suit required fire rating. These slabs are designed to be cut on site to suit individual floor void depth (plus allowance as per CF 563 for compression fit)

Pre-cut products (Square edged)

1200mm long x void depth (plus allowance as per CF 563 for compression fitting).
 Thickness: 75, 90, 120 & 175mm to suit required fire rating.
 (Note 175mm is supplied with rebated overlap as standard)

Technical Advice

For further information please contact our technical dept. at the address below.

A Material Safety Data Sheet is available upon request.

Fixing Brackets**Standard Fixing Brackets:**

125mm x 1mm galvanised steel. Supplied flat with no holes for folding and drilling on site.

B65/110 for voids up to 150mm spacings @ 600mm ctrs.

B195 for voids from 151mm to 240mm spacings @ 600mm ctrs

B355 for voids from 241mm to 400mm spacings @ 600mm ctrs

B355 for voids from 401mm to 500mm spacings @ 400mm ctrs

Structural Fixing Brackets:

125mm x 3mm galvanised steel. Supplied flat with no holes for folding and drilling on site.

B600 for voids from 601mm to 900mm spacings @ 400mm ctrs.

B900 for voids from 901mm to 1200mm spacings @ 400mm ctrs

Standard Foil Tape**RFT120/45**

(120mm wide in 45m rolls)
 For smoke barrier applications, tape from product to product.

High Specification Foil Tape**RF/SFT100/1 0**

(100mm wide in 10m rolls)
 For plenum lining applications, tape from product to concrete structure and from curtain wall system to product.

Lamatherm Fire and Acoustic Gap Sealant

310ml cartridge for use as an adhesive or sealing of small voids up to 25mm.

Lamatherm Fire Rated Silicone Gap Sealant

310ml cartridge for sealing of small voids with movement requirements.



**APPROVED PRODUCT
 CF 563**