

SUNSCOOP™ TUBULAR ROOFLIGHTS

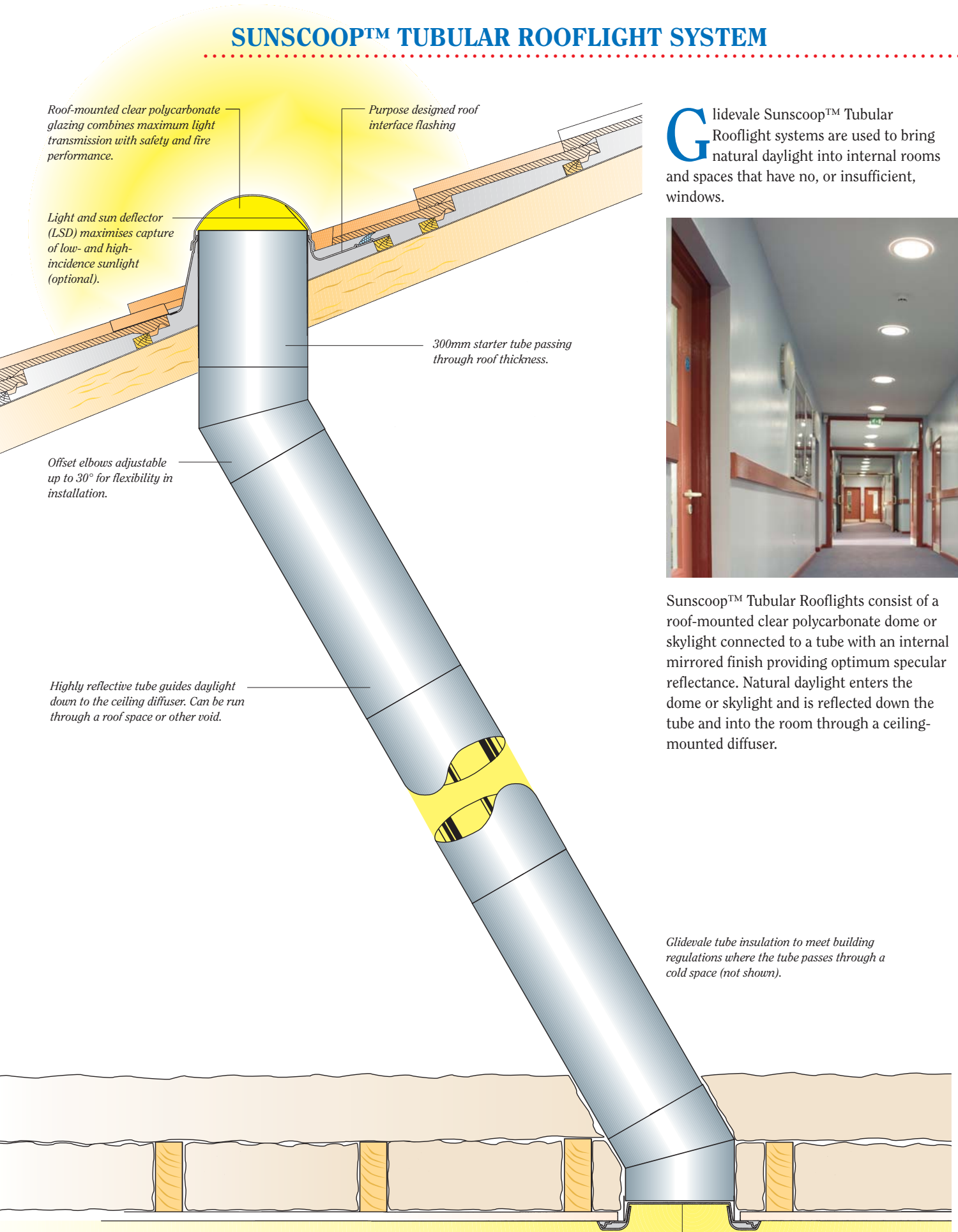

SUNSCOOP™ TUBULAR ROOFLIGHT SYSTEM



Roof-mounted clear polycarbonate glazing combines maximum light transmission with safety and fire performance.

Purpose designed roof interface flashing

Light and sun deflector (LSD) maximises capture of low- and high-incidence sunlight (optional).

300mm starter tube passing through roof thickness.

Offset elbows adjustable up to 30° for flexibility in installation.

Highly reflective tube guides daylight down to the ceiling diffuser. Can be run through a roof space or other void.

Glidevale Sunscope™ Tubular Rooflight systems are used to bring natural daylight into internal rooms and spaces that have no, or insufficient, windows.



Sunscope™ Tubular Rooflights consist of a roof-mounted clear polycarbonate dome or skylight connected to a tube with an internal mirrored finish providing optimum specular reflectance. Natural daylight enters the dome or skylight and is reflected down the tube and into the room through a ceiling-mounted diffuser.

Glidevale tube insulation to meet building regulations where the tube passes through a cold space (not shown).

Ceiling diffuser provides maximum even light spread. Range of options.

SUNSCOOP™ TUBULAR ROOFLIGHT SYSTEM

Proven benefits of natural light

Scientific studies have shown the positive benefits of natural daylight in a range of applications. For example, it can promote faster recovery of hospital patients and better performance by factory workers and pupils in schools (references available from Glidevale Technical Services).

Glidevale Sunscope™ Tubular Rooflight systems, used as a complement to artificial lighting, can considerably reduce the annual energy consumption of any building, thereby reducing CO₂ emissions. An investment in Glidevale Sunscope™ Tubular Rooflight systems is an investment in energy conservation.

Sunscope™ advantages

- Highly effective at delivering light into internal and badly-lit spaces.
- System design and performance are backed by an unrivalled programme of research.
- Energy saving - reduces the need for artificial lighting.
- Natural daylight has positive benefits over artificial lighting.
- Wide range of applications - houses, flats, schools, hospitals, commercial and industrial buildings.
- Ideal for bathrooms, stairways, corridors and other dark areas.
- Range of sizes for different requirements.
- Simple and reliable installation.
- Wide range of purpose-designed roof interface flashings to suit most roof coverings.
- Can be used on pitched and flat roofs.
- Adjustable elbows give flexibility of siting.
- Complete system meets the thermal requirements of the latest building regulations.



TECHNICAL BACKGROUND



External lux sensor with shade ring for measuring diffused light levels



Monitoring of three tubular rooflights simultaneously

Perception of light levels

The sensitivity of human eyes varies according to actual light level. They are highly adaptive to the very wide range of light levels in which we need to function. The difference in light levels between 'bright' daylight and 'dim' light is some 5 orders of magnitude, yet the eye readily adapts and enables humans to see well at both extremes.

As a consequence of this adaptability, actual light levels (measured in lux), are very difficult for humans to relate to.

In order to accurately measure light as sensed by the human eye to determine actual performance of Sunscope systems, a lux sensor is used, and the light level measured is termed illuminance.

The Table below shows typical light levels in lux under different conditions for both natural and artificial light.

These can be compared with the results of Glidevale Sunscope systems shown later under the heading System performance on page 6.

Typical light levels (lux)

Condition	Light level (lux)
<i>Natural light</i>	
Clear summer day with direct sunlight	80 000 - 100 000
Bright cloudy day, no direct sunlight	30 000 - 50 000
Overcast day, no direct sunlight	10 000 - 20 000
Twilight	1
Clear full moonlit night	0.1
Starlight night	0.001
<i>Artificial light</i>	
Candle at 1.0m	1
Side roads at night	5
Main roads at night	15
60W pearlescent bulb, no shade	50*
100W pearlescent bulb, no shade	60*
150W pearlescent bulb, no shade	160*

* Actual measurements taken by SILSOE Research Institute at 1.5m below the lamp with a white ceiling above.

Sunscope™ performance monitoring

Unique test programme

The performance of the Glidevale Sunscope™ Tubular Rooflight system has been firmly established by a unique and extensive programme of testing over a five-month period.

The level and intensity of this research under real conditions has provided Glidevale with ground-breaking knowledge, unparalleled in the tubular rooflight industry.

This exclusive monitoring work provides realistic and reliable data on the Glidevale Sunscope™, giving a sound practical basis for system design (see Sunscope™ System Performance).

The research

The research programme has been carried out by SILSOE Research Institute (SRI) to quantify the performance of the Glidevale Sunscope™ Tubular Rooflight system.

The features of this programme were:

- A systematic study of the Sunscope™ product range
- Extensive measurements over five months in the summer/autumn period.
- Natural light conditions ranging from bright, clear skies to overcast conditions.
- Simultaneous monitoring of three Sunscope™ systems of different diameters and a range of lengths, mounted close together on a roof.
- Measurements of total, diffuse and direct external light and internal light levels every 12 seconds for each data run.
- Supplementary controlled laboratory measurements under artificial light conditions.

This project provided directly comparable measurements of system performance, enabling the contributions of individual components to be quantified. This is now being extended to investigate further the science of tubular rooflight systems.

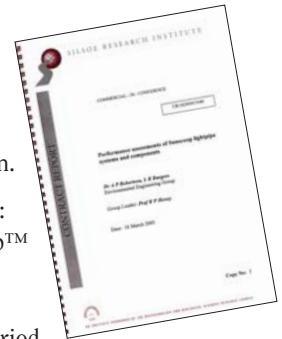

Internal view of different diameter tubular rooflights under test

SUNSCOOP™ SYSTEM PERFORMANCE

Light output monitoring

The extensive and prolonged monitoring of Glidevale Sunscope™ systems by SRI under a wide range of conditions provides for the first time realistic and reliable performance data.

The light output from the Sunscope™ system depends on:

- Diameter and length of tubing, and offset angles if any.
- External sky conditions, and light levels measured in lux.

The distribution of the light in the room depends on:

- Diffuser type.
- Wall, ceiling and floor reflectance.

Table A overleaf shows measured light output for a full range of Sunscope™ systems.

For comparison, Table B overleaf shows measurements of light output of standard electric lamps under the same conditions.

All readings are taken 1.5m below the diffuser, that is at desk level of a typical room with a 2.4m floor-to-ceiling height, and in a blacked-out space with non-reflective walls, floors and ceilings. The figures are therefore conservative measures of light levels likely to be achieved in any practical situation where there is some reflection from walls, floors and ceilings.

A sophisticated computer program is now being developed to accurately predict light levels of Sunscope™ systems, based directly on the SRI monitoring. For further information please consult Glidevale Technical Services.

Sunscope™ light output monitoring: typical example

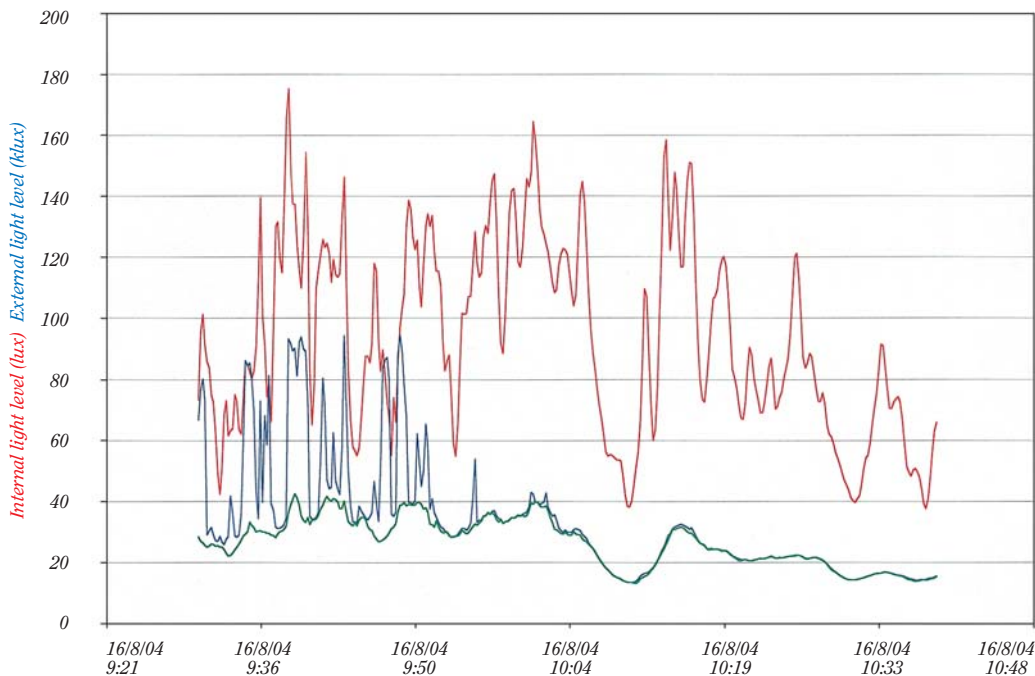

Tube diameter 250mm, SR95 coating, system length 2.7m. Measured 1.5m below Sunscope™ ceiling diffuser, in a totally black room with no reflected light.

Internal light level
 External light level with sun breaking through clouds
 External diffuse background light level

SUNSCOOP™ SYSTEM PERFORMANCE



Internal view of different diameter tubular rooflights under test

Table A Sunscope™ light output performance

Glidevale Sunscope™ system with SR95 Specular tubing, LSD and standard ceiling diffuser. Other conditions - see text on page 5.

Tube diameter	System length	External light levels (klux)						
		100	60	50	40	30	20	10
		Internal light levels (Sunscope™ light output) (lux)						
250mm	1.00m	261	196	166	141	89	53	29
	1.50m	240	174	150	132	87	52	28
	2.00m	221	153	135	123	84	50	27
	2.50m	202	135	121	114	81	48	26
	3.00m	186	118	108	105	77	46	25
	3.50m	170	103	96	95	73	44	23
	4.00m	156	90	85	86	67	41	22
	4.50m	144	78	75	76	61	38	20
	5.00m	133	69	66	66	55	34	18
	5.50m	123	61	58	56	48	31	16
350mm	1.00m	282	276	244	206	134	78	43
	1.50m	280	252	225	200	135	78	43
	2.00m	279	230	207	192	134	77	42
	2.50m	275	209	189	183	132	75	41
	3.00m	268	189	172	173	128	73	40
	3.50m	259	171	156	161	122	70	38
	4.00m	248	154	141	147	115	67	37
	4.50m	233	139	127	132	106	63	34
	5.00m	216	126	113	116	95	58	32
	5.50m	197	113	101	98	82	53	29
530mm	1.00m	572	435	369	297	201	128	66
	1.50m	540	390	335	284	198	122	64
	2.00m	509	348	304	270	193	116	62
	2.50m	477	311	274	255	186	110	59
	3.00m	446	277	248	238	178	104	56
	3.50m	414	246	223	221	168	98	53
	4.00m	383	220	201	202	157	92	50
	4.50m	352	197	181	182	144	86	47
	5.00m	321	178	163	160	129	79	44
	5.50m	290	162	148	138	113	72	40
6.00m	6.00m	259	151	134	114	96	65	36
	6.50m	228	143	124	90	76	58	32
	7.00m	197	139	115	64	55	51	28

Table B Artificial light levels

For comparison, measurements of artificial light levels by SRI under the same conditions as for Table A, see above.

Standard electric bulbs: Philips ClassicTone 240V 1000-hour with pearlescent finish, no shade.

Bulb	Light level (lux)
60W	50
100W	60
150W	160

LAYOUT AND SITING

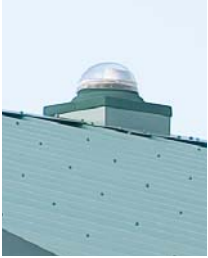

System layout

The Sunscope™ tubing can pass through a roof space or other void.

For maximum effectiveness it should be as straight as possible. However, since it is often impractical to site the ceiling diffuser directly below the roof-mounted glazing, the tubing system allows an offset by means of two elbows, one at roof level and one at ceiling level. They are adjustable up to 30° from vertical.

There should be no other bends or offsets in the tubing as monitoring has shown that these will adversely affect performance.

Typical layouts

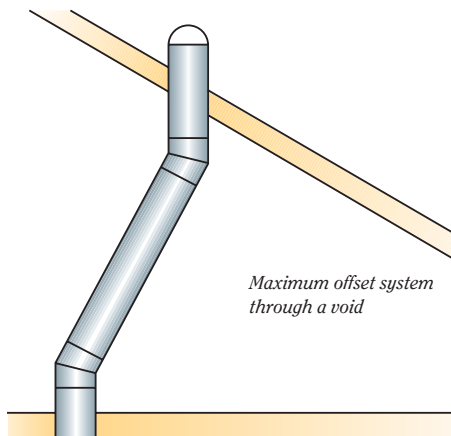
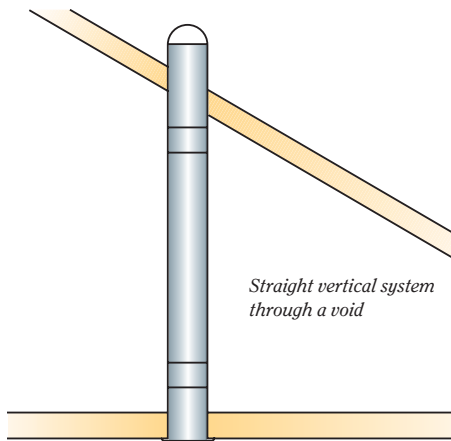
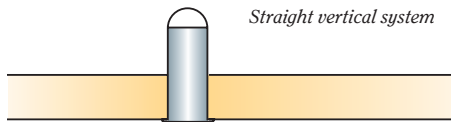

Siting

Where possible the roof-mounted glazing should be located on a south-facing slope to gain the maximum amount of daylight under both direct and diffuse conditions.

The light and sun deflector, if specified, should be orientated to face due south.



Factors which need to be considered when siting a Sunscope™ include:

- Location of the room to be lit and suitable position of the ceiling diffuser.
- Roof space obstructions.
- Proximity of other buildings, trees etc, which may cast shadows at certain times of the day or year.



SUNSCOOP™ COMPONENTS

Roof-mounted glazing

Glidevale Sunscope™ glazing is manufactured from 3.0mm clear uv-stabilised polycarbonate with 88% light transmission.

This has a 10-year warranty (supported by the polycarbonate manufacturer) against loss of impact strength, excessive yellowing and loss of light transmission.

The warranty also covers any effects of the forming process.

Polycarbonate secondary glazing is also available to maximise insulation levels along with the use of Glidevale tube insulation.



Light and sun deflector (LSD)

This unique optional device is fitted under the roof glazing and intercepts direct sunlight that would otherwise miss the top of the system at both low and high incident angles, reflecting it down the tube.

Monitoring has shown that a south-facing LSD can increase the light level at the ceiling diffuser by 20% or more in direct sunlight conditions.



Tubes and elbows

Tubes and elbows are anodised aluminium with a multi-layer specular coating which ensures pure white light with no colour shift, even after multiple reflections down the light tube. Two coatings are available:

SR98 Mirror incorporates a pure super silver layer and has a total reflectance of 98%.

SR95 Specular incorporates a pure aluminium layer and has a total reflectance of 95%.

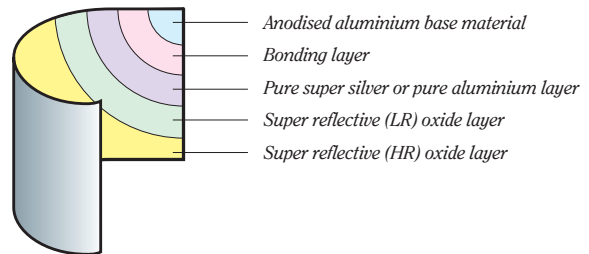

Both are a multi-layer optical coating system which is atomically bonded to the substrate. Laminated or glued reflective sheets are not used.

Both have a 25-year product warranty which guarantees that the material will not splinter, yellow, darken, peel off, blister, crack or develop any other surface degradation which could reduce overall reflectivity, even after prolonged uv exposure. The finished materials are electrostatically neutral and will not attract airborne dust even during installation.



Sizes

Tube diameter: 250mm, 350mm or 530mm.

Starter tube length: 300mm.

Intermediate tube lengths: 600mm. Can be cut as required on site.

Elbow length (straight): 200mm for 250 and 350mm tube, 300mm for 530mm tube.

Elbow adjustment: up to 30°.

SUNSCOOP™ COMPONENTS



Integral electric light fitting

The Sunscope™ can be supplied with an optional integral electric lighting fitting (2 on 530mm systems) with a 13W or 20W low-energy lamp (equivalent to a 65W or 100W conventional lamp). This avoids the need for an additional light fitting for night-time use.



Light-attenuating dampers

Control over the light level entering the room may be required at certain times, for example in conference rooms, lecture theatres, classrooms and hospital wards.

The optional Sunscope™ motorised light-attenuating damper provides this control; it is actuated from a wall switch, separately available.

Fire protection collars

In longer Sunscope™ systems the tubing may pass through an intermediate floor or ceiling that provides fire separation. As with any ducted system it is important that the tubing does not form a path for fire.

Fire protection collars providing up to 120 minutes fire resistance to BS 476: Part 20: 1987 are available for all diameters of Sunscope™ tubing.

Glidevale Tube Insulation

Specifically designed to contribute to the overall thermal performance of the system, This is a multi-layer air-bubble/foil insulation with a low-emissivity aluminium foil encapsulated in polyethylene on both faces. All exposed tubes and elbows within unheated voids, such as loft spaces, should be lagged with Glidevale tube insulation to reduce heat loss and the risk of condensation within the tube.

Thermal insulation

Building Regulations (England and Wales) Approved Documents L1 and L2 require a U-value of 2.2 W/m²K for all rooflights.

Sunscope™ rooflights meet this requirement when fitted with either a polycarbonate secondary glazing skin and/or tube insulation in unheated spaces.



Ceiling diffusers

Circular ceiling diffuser

The standard recessed ceiling diffuser for all tube sizes, designed to maximise light transmission. Its translucent surface provides privacy and spreads the light efficiently throughout the room.

Manufactured from diffused polycarbonate with white-capped ABS ceiling ring to hide fixings. Also available in chrome or brass finish.



Skyview diffuser, circular

Optional for all tube sizes. The innovative Skyview diffuser consists of a grid of fresnel lenses which provides a wider spread of light without excessive losses and enables the sky to be viewed.



Skyview diffuser, square

Optional for 530mm tube only. Similar to the circular Skyview but mounted in a 600 x 600mm polycarbonate panel which can be fitted in a suspended ceiling.



SUNSCOOP™ COMPONENTS

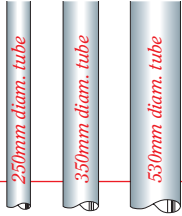

Roof interface flashings

A range of dedicated roof flashings is available for different types of pitched and flat roof coverings, as shown below.

250mm diam. tube	350mm diam. tube	530mm diam. tube	
✓	✓	n/a	Versatile, suits most interlocking roof tiles ●
✓	n/a	n/a	Plain tile flashing
✓	✓	n/a	Slate soaker
✓	✓	✓	Universal Top ●
✓	✓	✓	Universal Top with integral skirt ●
✓	✓	✓	In line/traditional skylight ●

Flat roof flashings

✓	✓	✓	Universal Top ●
✓	✓	✓	Universal Top with integral skirt ●
✓	✓	✓	Universal Top with integral PVC-U insulated upstand

- Not suitable for single clay pantiles, plain tiles, Forticrete Centurion tiles, Goxhill Gaelic tiles, or interlocking slates - use Universal Top
- Requires a site-fabricated upstand.
- Suitable for all types of tile and slate roof coverings

Appearance

All flashings are manufactured from ABS and are treated with a uv-stable polymeric resin. Standard colours are red, brown, grey, terracotta and red streak for tiles, and blue/black for slates. Colour matching to specific roof coverings including composite panel and standing seam systems is also available.

To enhance appearance on pitched roofs, the Universal Top is available with an integral skirt which can be colour-matched to the roof covering.

Health and safety

The Sunscope™ glazing and flashings have been impact-tested to EN 1873 Modular Rooflights and may be deemed to be non-fragile for HSG33 Safety in Roofwork.

The Sunscope™ glazing and flashings have an AA fire rating to BS 476: Part 3: 2004, and can therefore be used on roofs without restriction on number, spacing or position.

Pitched roof flashings



Versatile



Plain tile flashing



Slate soaker



Universal Top

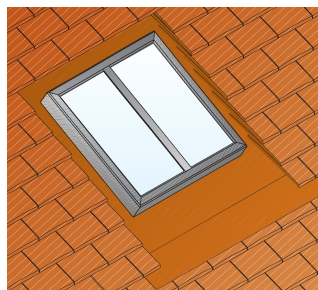

In line/traditional skylight. Traditional shown

Flat roof flashings



Universal Top with integral skirt



Universal Top with insulated upstand

TYPICAL INSTALLATIONS

Sunscoop™ on flat roof

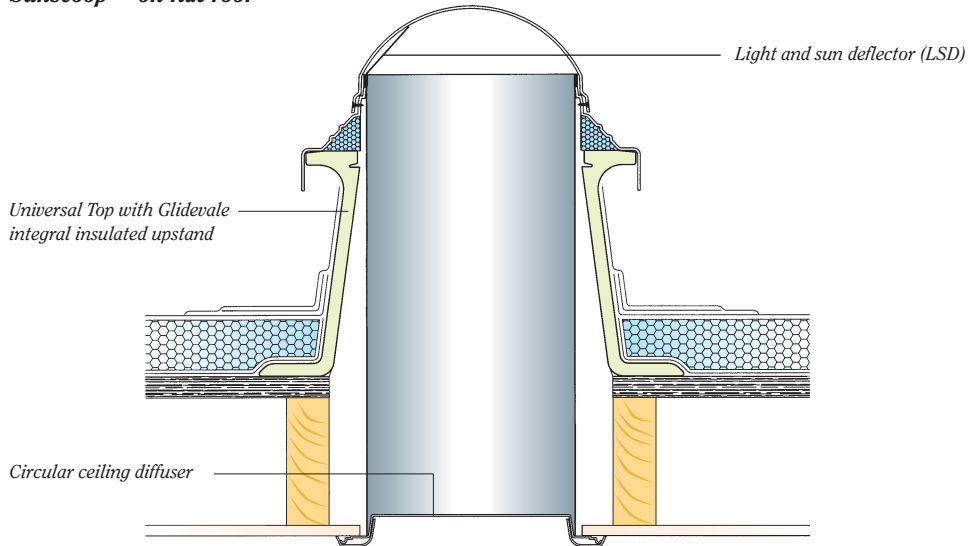

Sunscoop™ on pitched roof

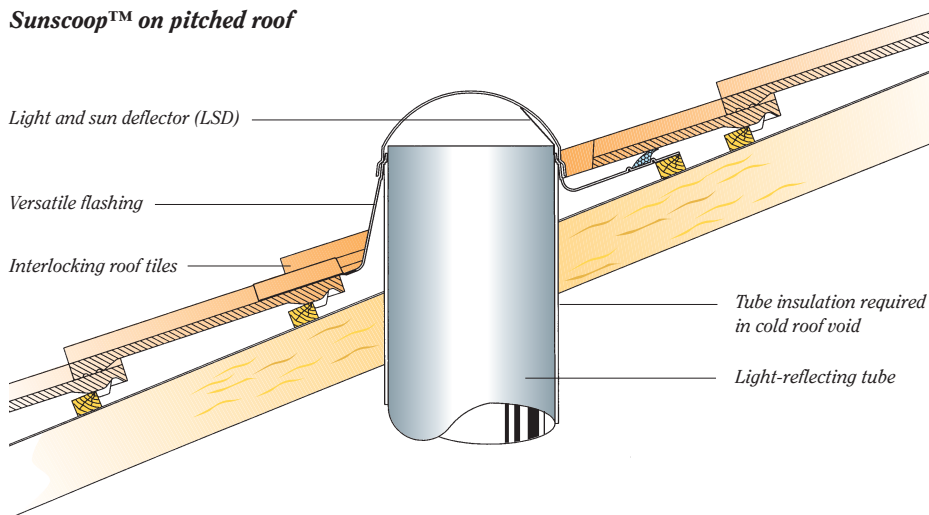

Sunscoop™ on standing seam roof

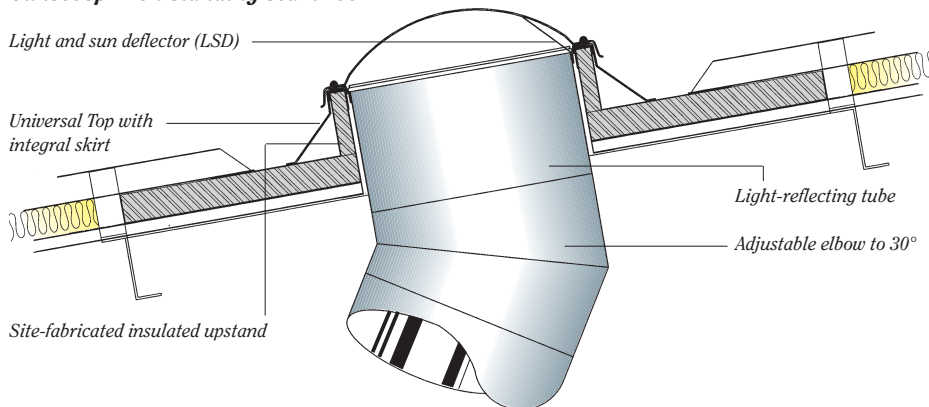

For more information on installation details please contact Glidevale Technical Services.

Specification clause

Natural lighting to ... rooms to be provided by means of Glidevale Sunscoop™ Tubular Rooflight systems comprising:
 Roof-mounted glazing of 3.0mm clear uv-stabilised polycarbonate, covered by 10-year warranty against loss of impact strength, excessive yellowing and loss of light transmission.
 Roof interface flashing of fire-retardant ABS treated with uv-stable polymeric resin.

In-line/Traditional skylight/
 Versatile / Plain tile / Slate soaker flashing / Universal Top with site-fabricated upstand / with integral skirt colour-matched to roof covering / preformed PVC-U insulated upstand.*
 Colour: red / brown / grey / terracotta / red streak, blue/black / colour-matched to roof covering.*
 To have AA fire rating to BS 476: Part 3: 2004.
 Tubes and elbows with multi-layer specular coating with 25-year warranty.

SR98 Mirror reflectance 98% / SR95 Specular reflectance 95%.*
 Tube diameter: 250mm / 350mm / 530mm.*
 Circular recessed ceiling diffuser of diffused polycarbonate with white-capped ABS ceiling ring / chrome / brass / Skyview diffuser circular / Skyview diffuser square.*

Options to be fitted: Light and sun deflector (LSD), polycarbonate secondary glazing skin, integral electric light fitting, light-attenuating damper, fire protection collar.*

All exposed tubes and elbows within unheated voids to be wrapped with Glidevale Tube insulation. System to achieve an overall U-value of 2.2W/m²K.*

Supplier: Glidevale Ltd, 2 Brooklands Road, Sale, Cheshire M33 3SS, Telephone: 0161 962 7113, Fax: 0161 905 2085, Email: info@glidevale.com

*delete as applicable

FURTHER INFORMATION

Quality Assurance

The Glidevale Sunscope™ system has been designed, developed and manufactured under a BS EN ISO 9001 Quality Management System. Independent auditing provides the user with assurance that the products will fulfil their intended purpose.



Services

For further information and advice on the selection and design of Sunscope™ installations please consult Glidevale Technical Services.

Other products

Glidevale market a wide range of other building products including:

Metro modular rooflights

Roof ventilation and roofing accessories

Underfloor and cavity wall vents

Underlays and membranes

Loft access traps.

Literature on these is available on request



GLIDEVALE LIMITED

2 Brooklands Road, Sale, Cheshire M33 3SS Tel: 0161-962 7113 Fax: 0161-905 2085
Email: info@glidevale.com Web: www.glidevale.com

Glidevale Limited maintains a policy of continuous development and reserves the right to amend product specifications without notice.

BPD

A member of the Building Product Design Group

